



The Institute of Road Transport Engineers NZ (IRTEENZ) 16th International Conference *Technology & Infrastructure - rapid change, constrained framework”*

August 2019

*At the heart of New Zealand's freight
& transport system*

The Macro View

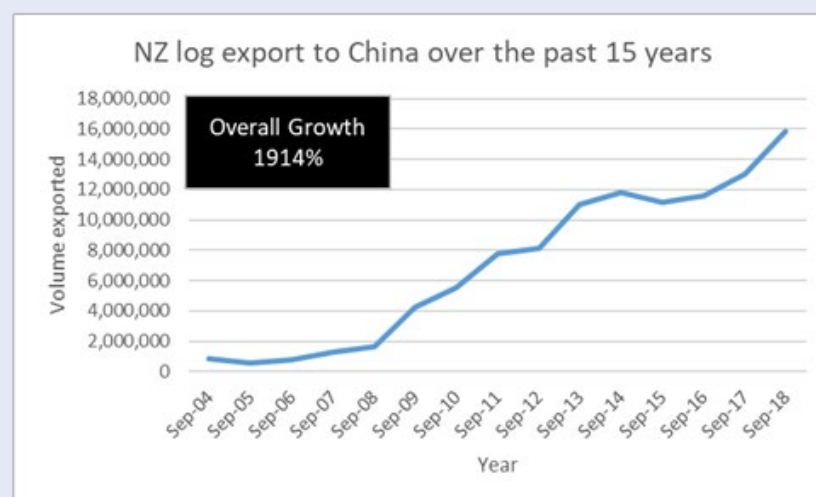
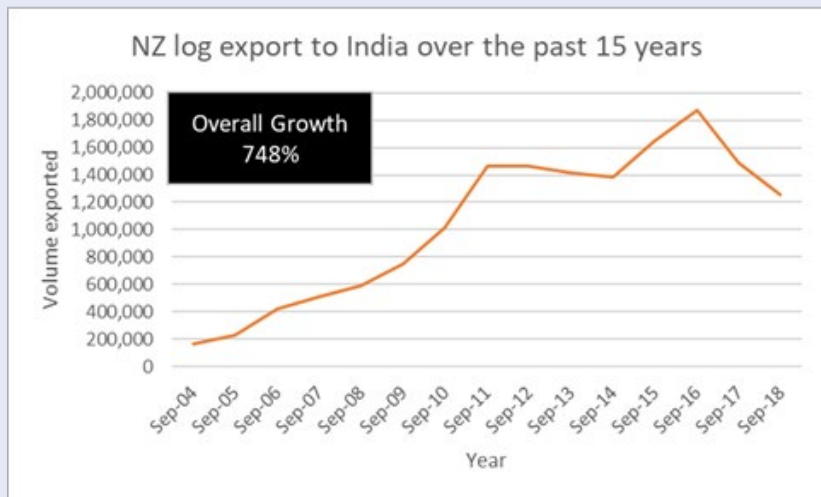
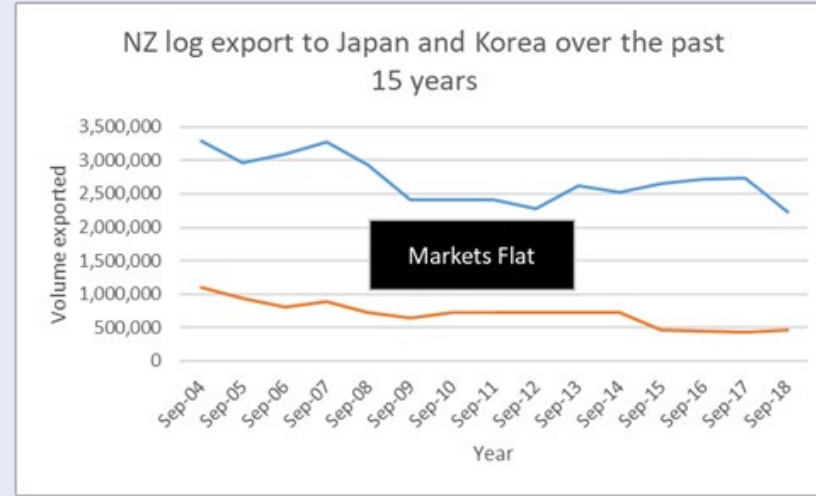
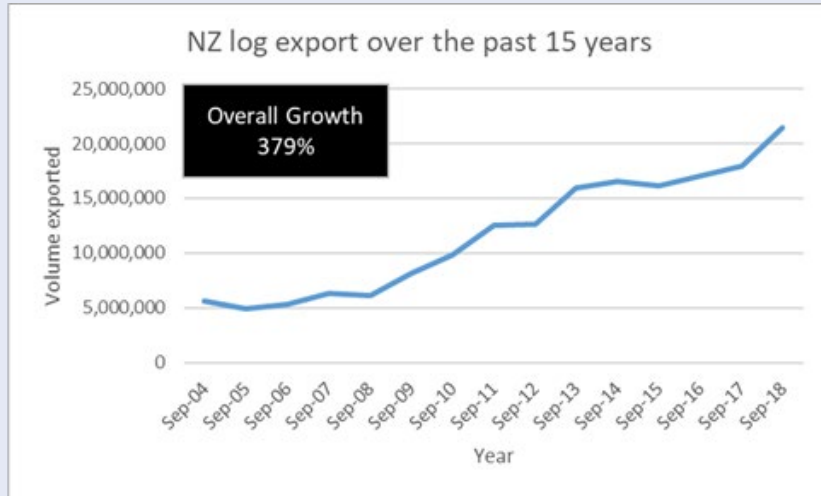

China China China

- **Population 1.5 billion and growing**
- **Movement to Urbanisation**
- **Increase in Middle Class**
- **Government Investment in Infrastructure on a massive scale**



China photos - Sawmilling



New Zealand Infrastructure Stretching Capacity

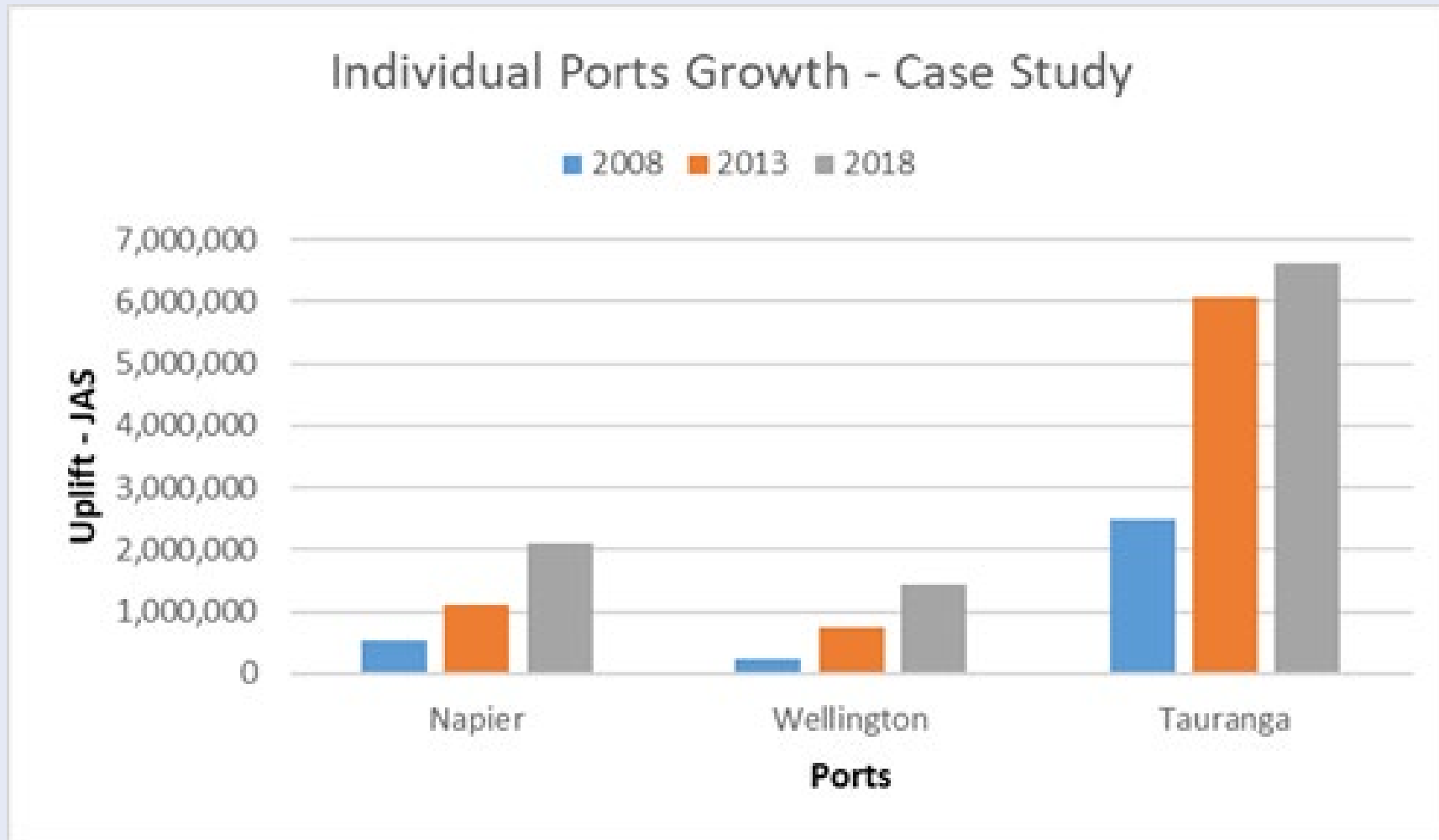

KiwiRail Numbers

- FY18 carried 3.6m tonnes of logs railed to port
 - equates to 120,000 truckloads
- 21% of NZ's log exports
- log volumes grown 40% in last 7 years
 - 20% of network volume
- 650 log wagons

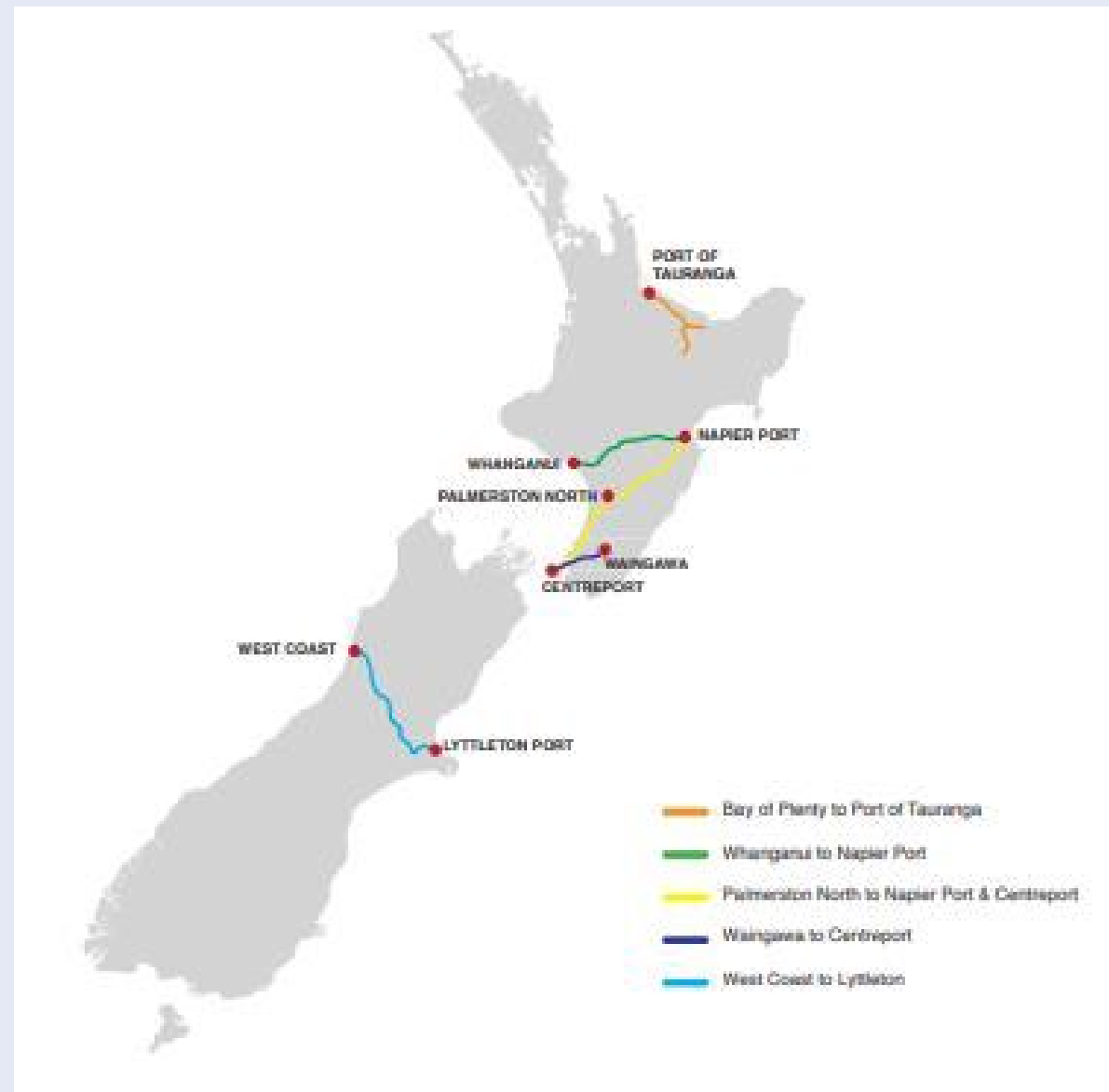

Billion Dollar Rail Investment next 2 years

\$331m

towards addressing legacy issues to improve reliability and resilience (e.g. maintaining existing tracks, signals, bridges, tunnels, new freight handling equipment and a new freight reservation and tracking system.)

\$375m

towards replacing 900 aging container wagons and start replacing the fleet of 48 South Island locomotives and some shunt engines; and improving the layout and efficiency of the major maintenance depots at Hutt and Waltham.

\$35m

for progressing procurement of two new, rail enabled ferries that will replace Aratere, Kaitaki and Kaiarahi.

\$300m

Potential to access up to \$300m from the PGF for regional rail projects.

Improving Resilience of NZ's Transport Network

- Consolidation at log hubs for rail to port
- Truck can carry more logs/day to hub than to direct to port

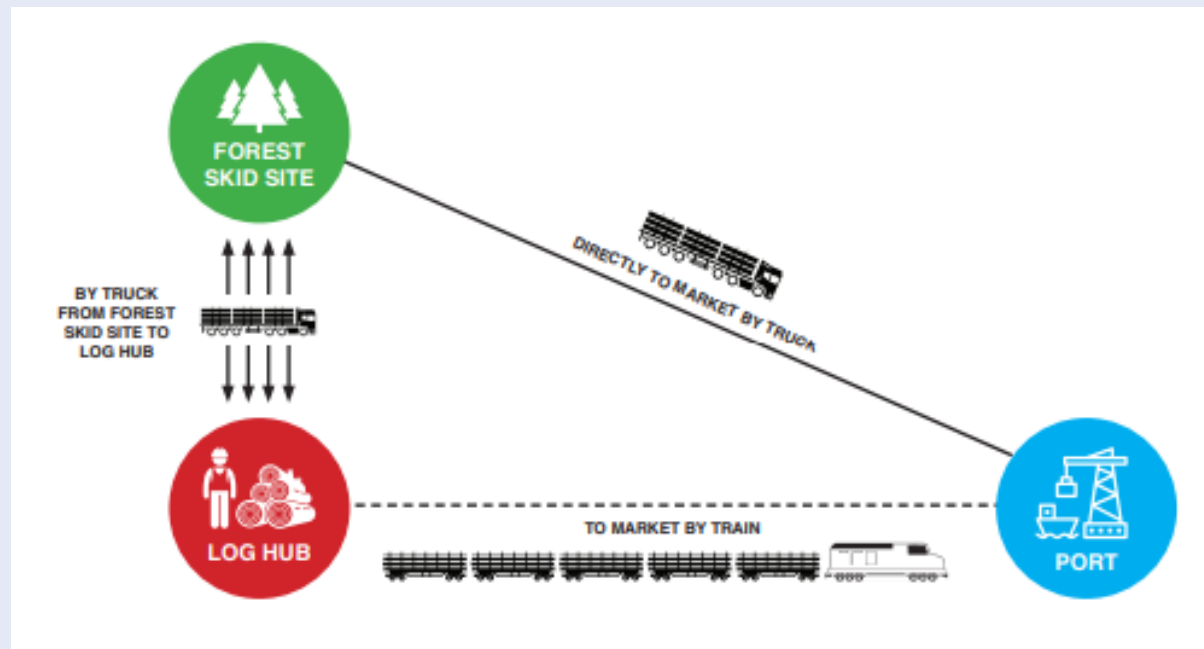

Hub developments

- Provide access to the rail network for forestry operators
- Aggregation point for road, rail and ports
- Supply chain buffer between log production and shipping
- Significant investment to set up requiring scale



Hubs Developments – CentrePort

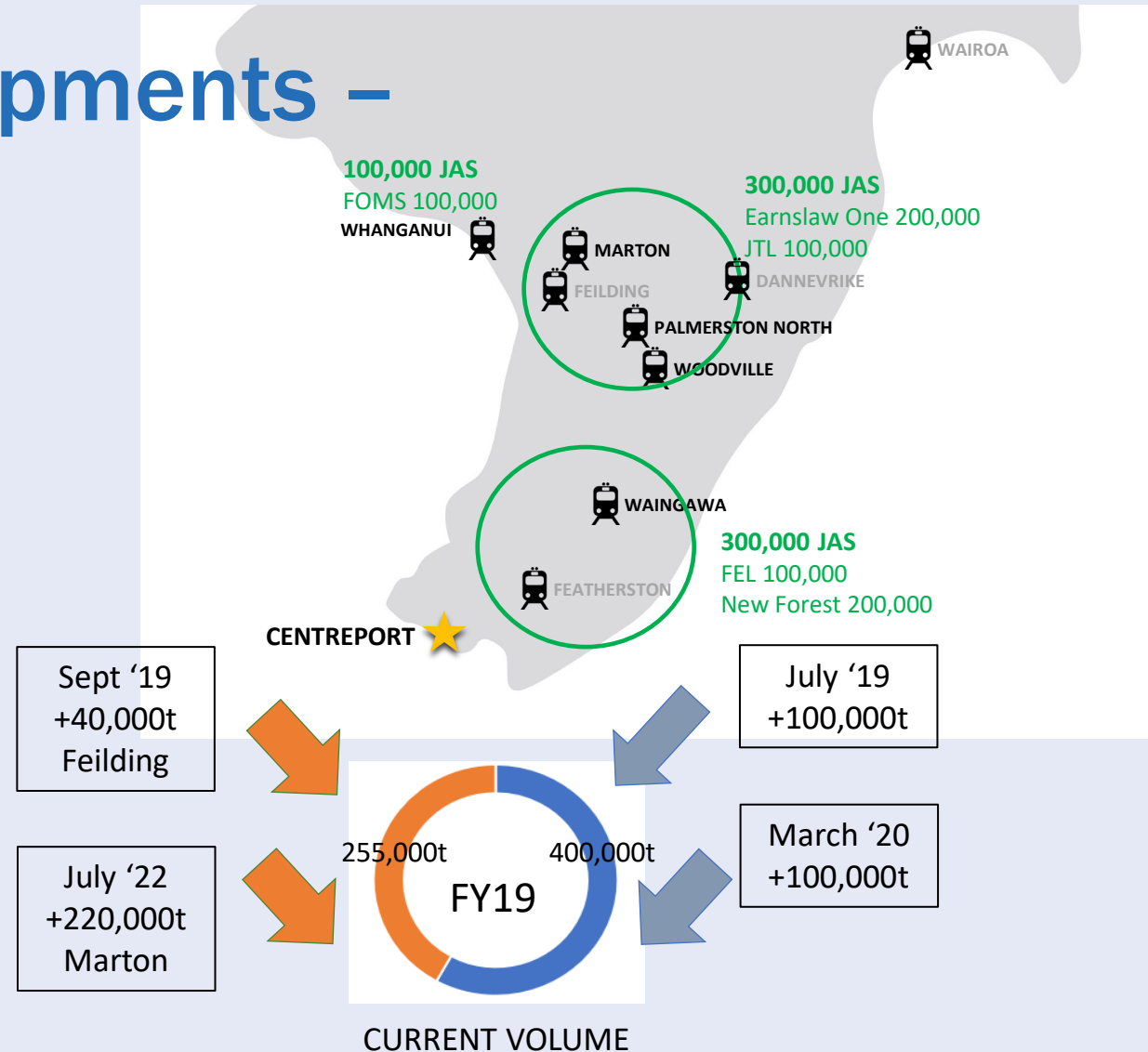

Repurposing wagons

- Investment in new container wagons releases wagons for conversion to carry logs, extending their economic life
- Low cost conversion with proven industry equipment supplier
- Aged fleet - 96% of fleet over 35 years old



A look into the future

- 60' log wagons with greater payload
 - ❑ leverage network capability
 - ❑ leverage existing 60' container wagons with cassettes
 - ❑ cassettes universal fit for standard 52' containers wagons
- BOP focus

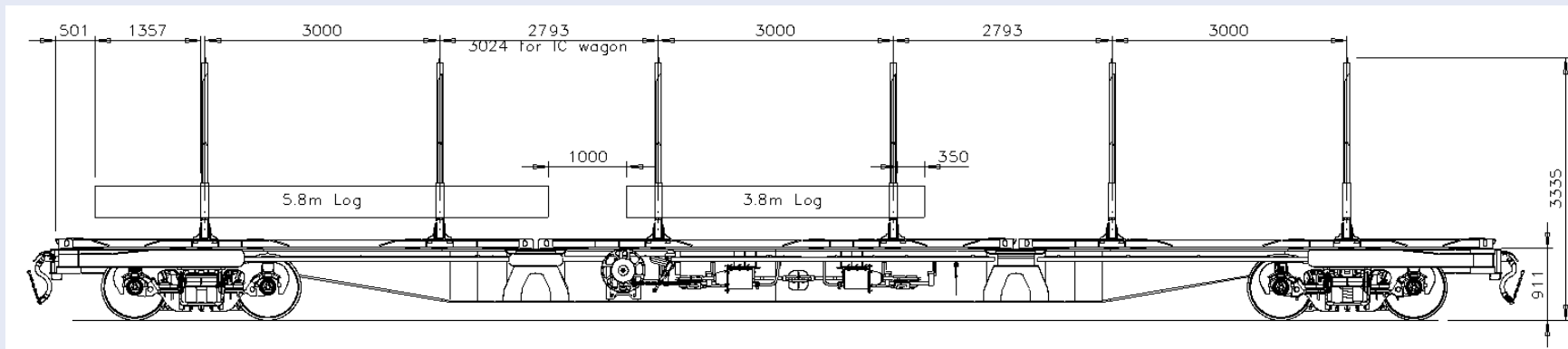

60' log wagon



Innovation

- Robots - Ticketing
- Scanners - Scanning
- Remoted Controllers Diggers
- MHC



More of this needed



Questions/comments?
