

The Future of Common Rail Injection Systems

Robert Kogai
Denso, Australia

Presented to the

Institute of Road Transport Engineers of New Zealand

SEVENTH INTERNATIONAL HEAVY VEHICLE SEMINAR

WELLINGTON

16 & 17 July 1998

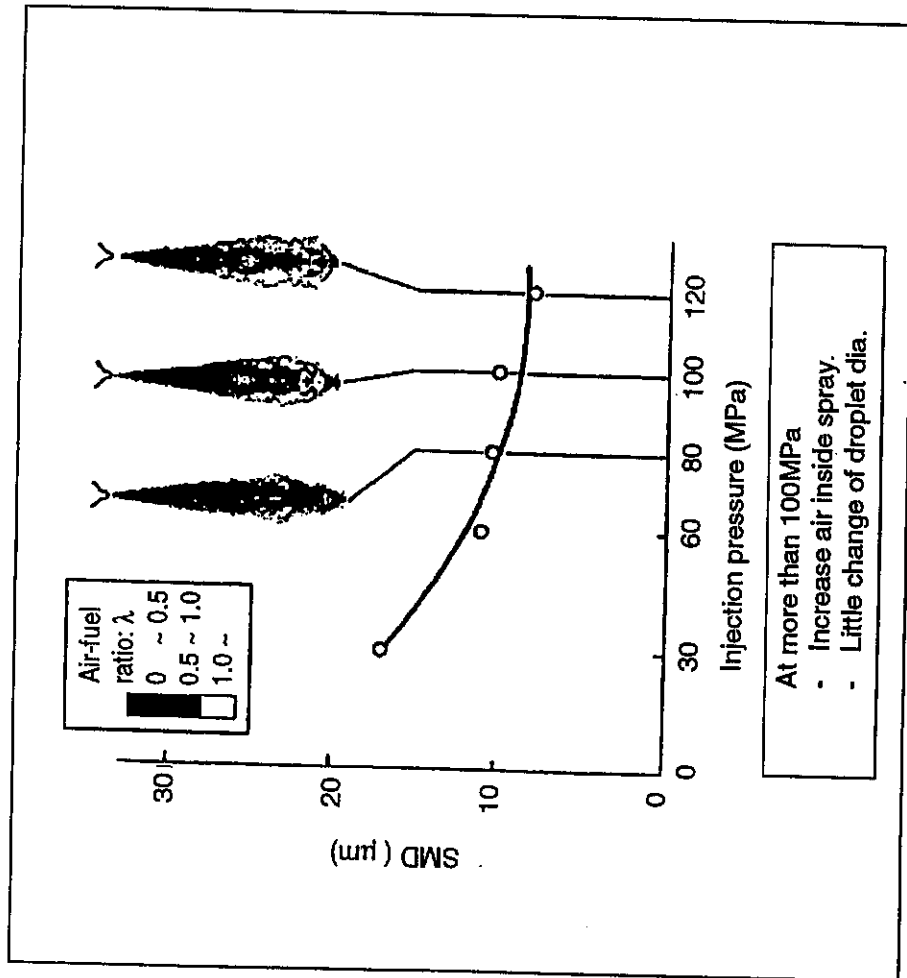

Figure 1: Effect of injection pressure on SMD and spray

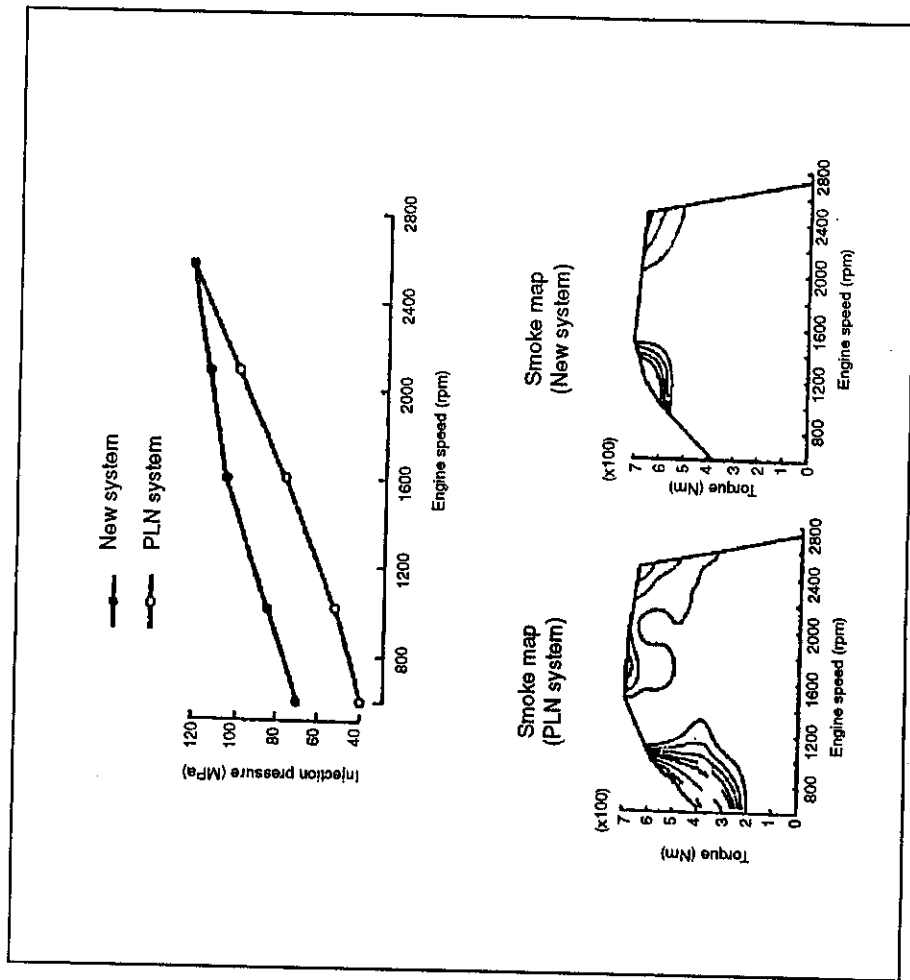

Figure 2: Comparison of smoke maps

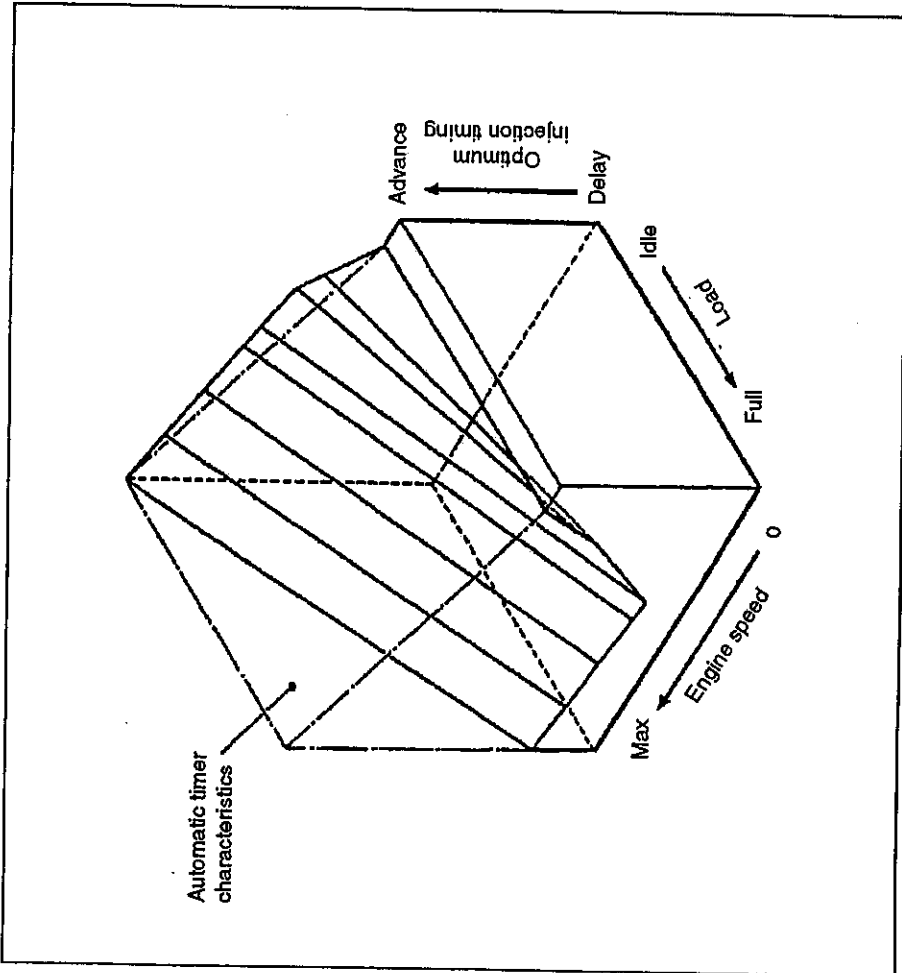

Figure 3: Example of optimum injection timing

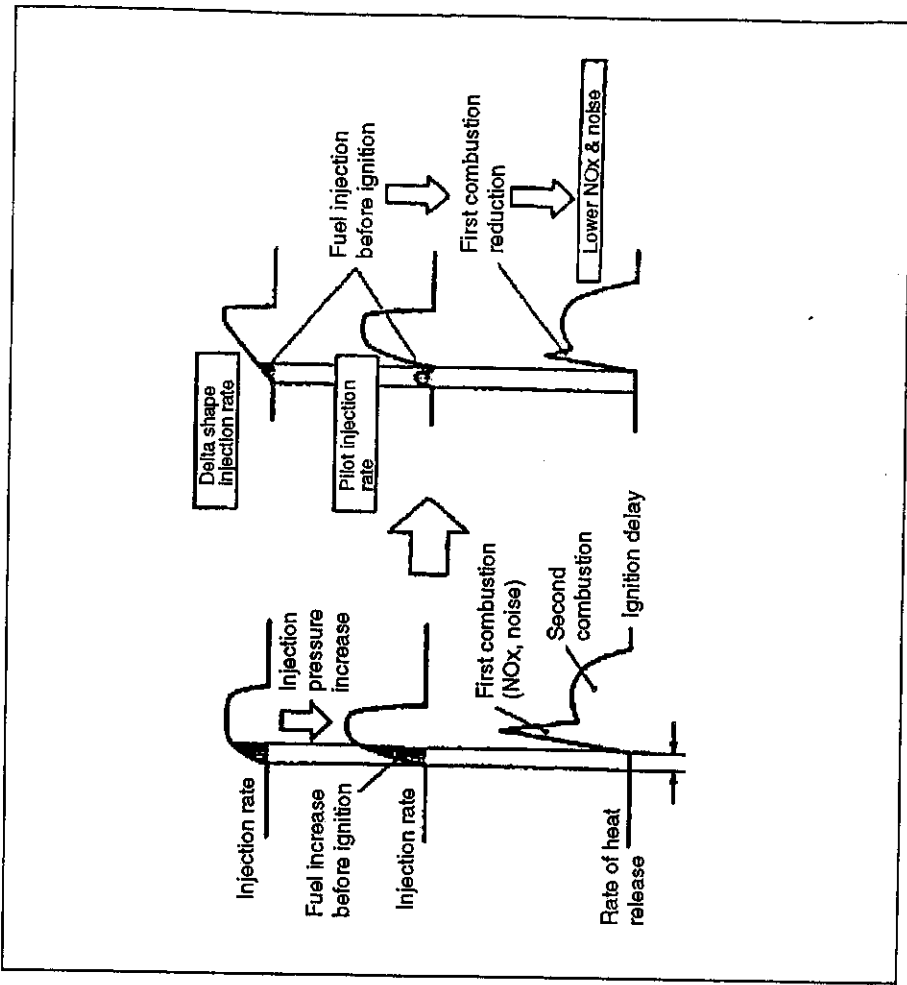

Figure 4: Effect of injection rate control

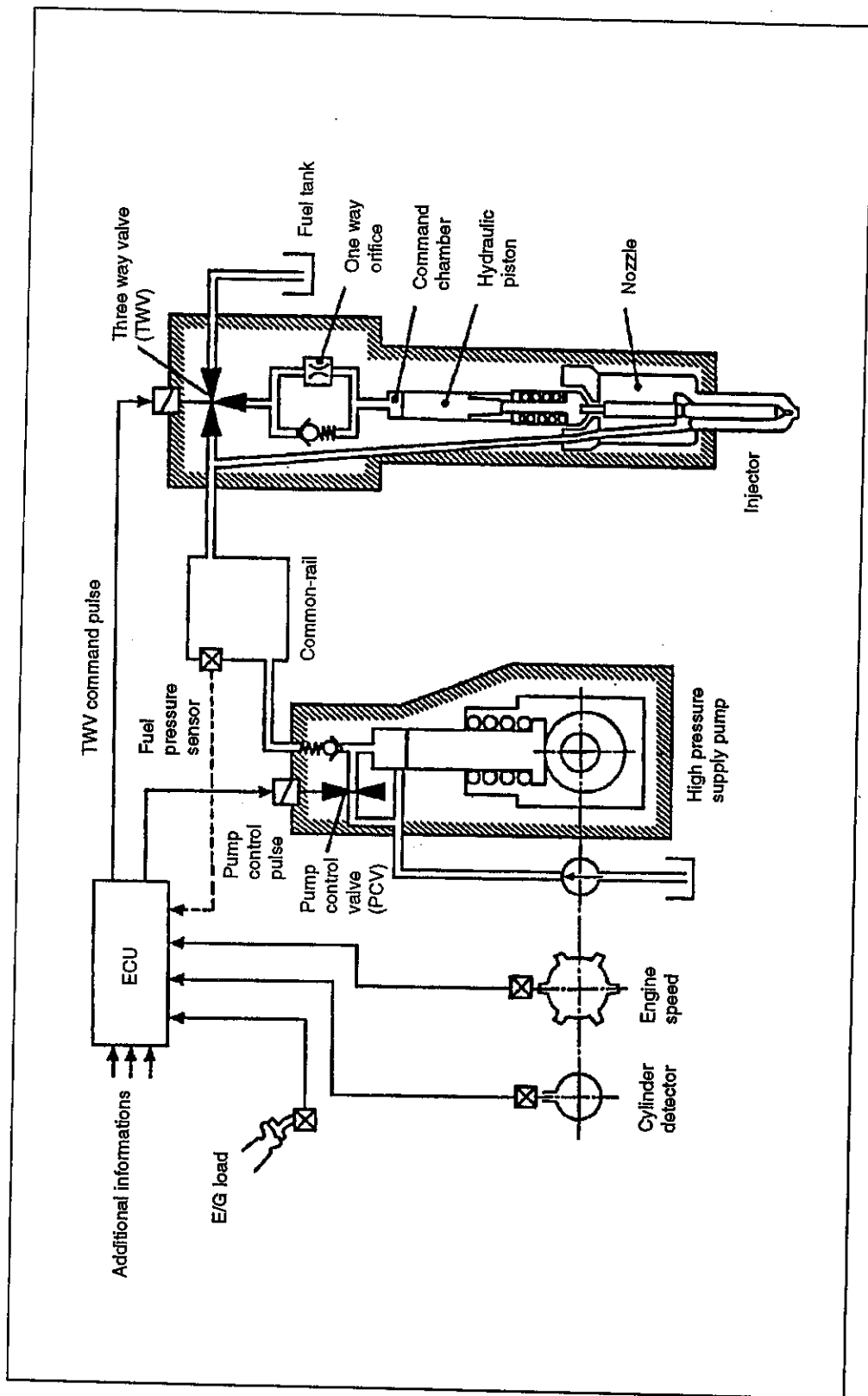

Figure 5: Schematic diagram of ECD-U2 system

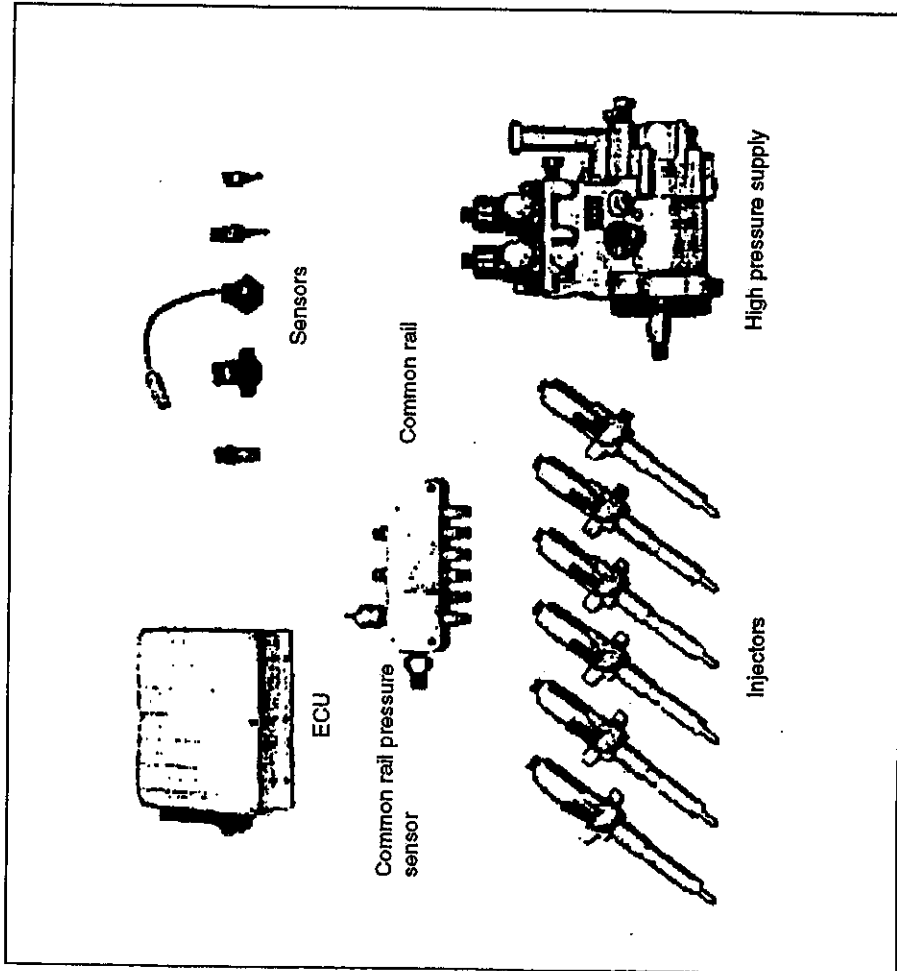

Figure 6: Whole system overview

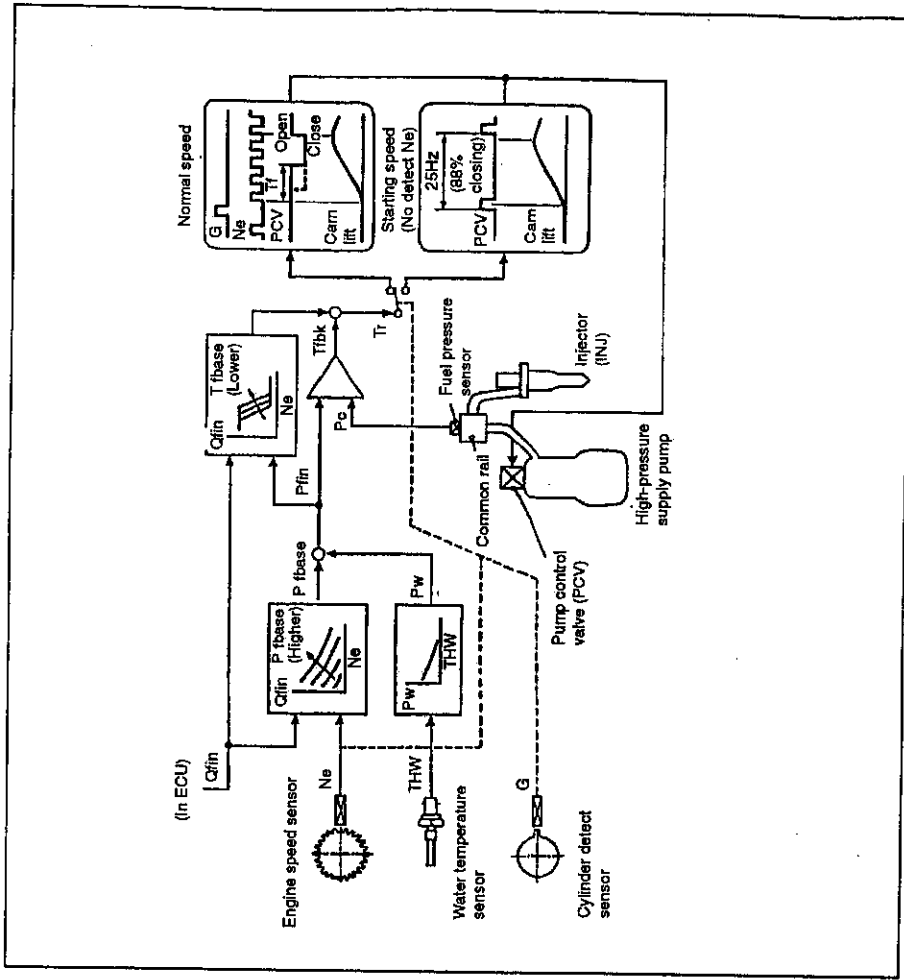

Figure 7: Block diagram of injection pressure control

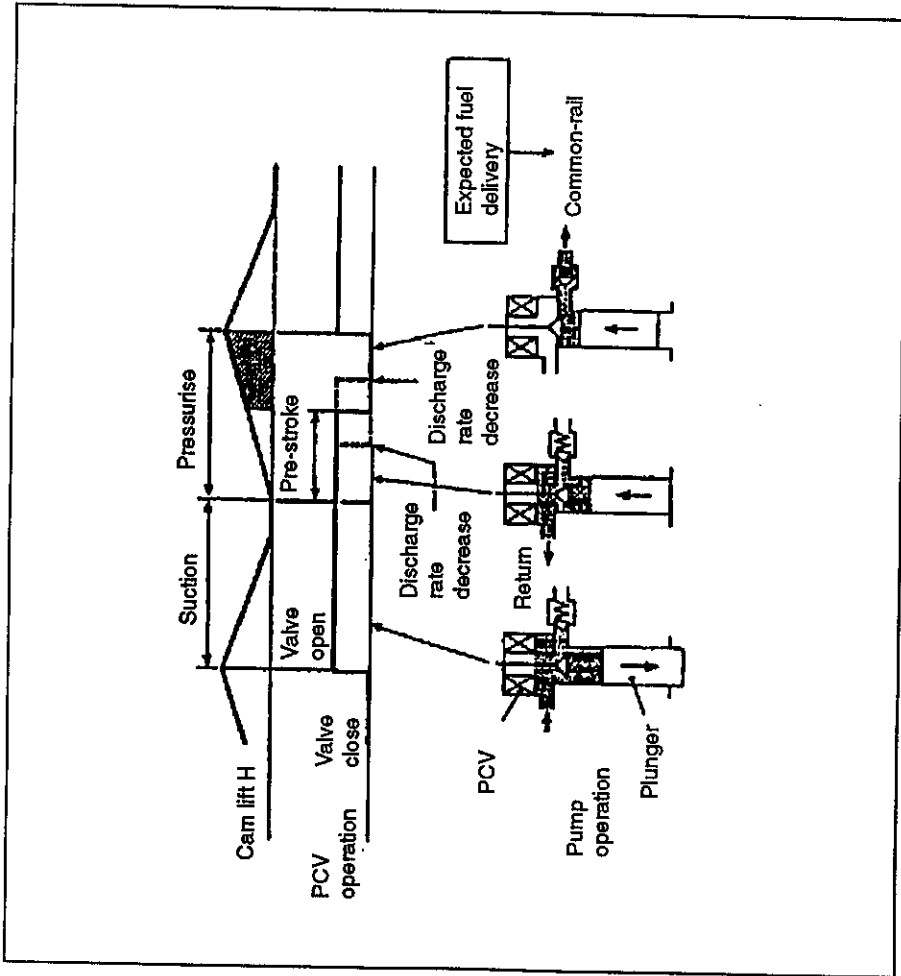

Figure 8: Control of high-pressure supply pump

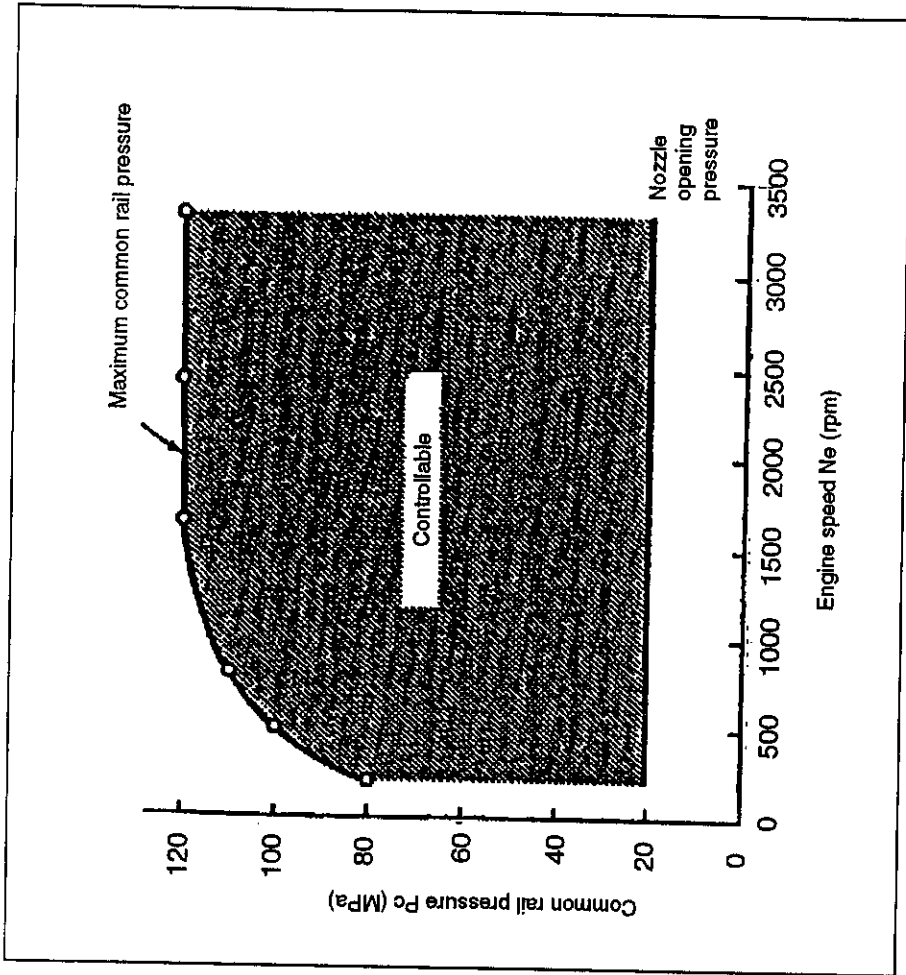

Figure 9: Maximum common rail pressure and control range

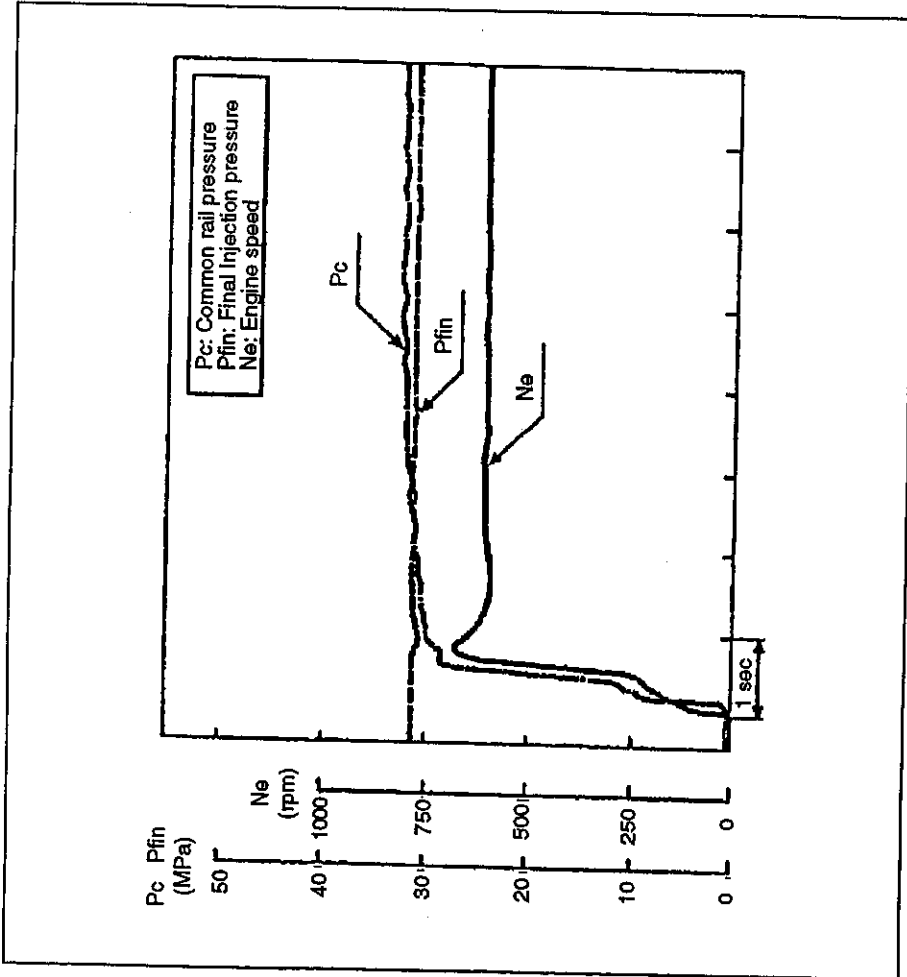

Figure 10: Pressure response at starting condition

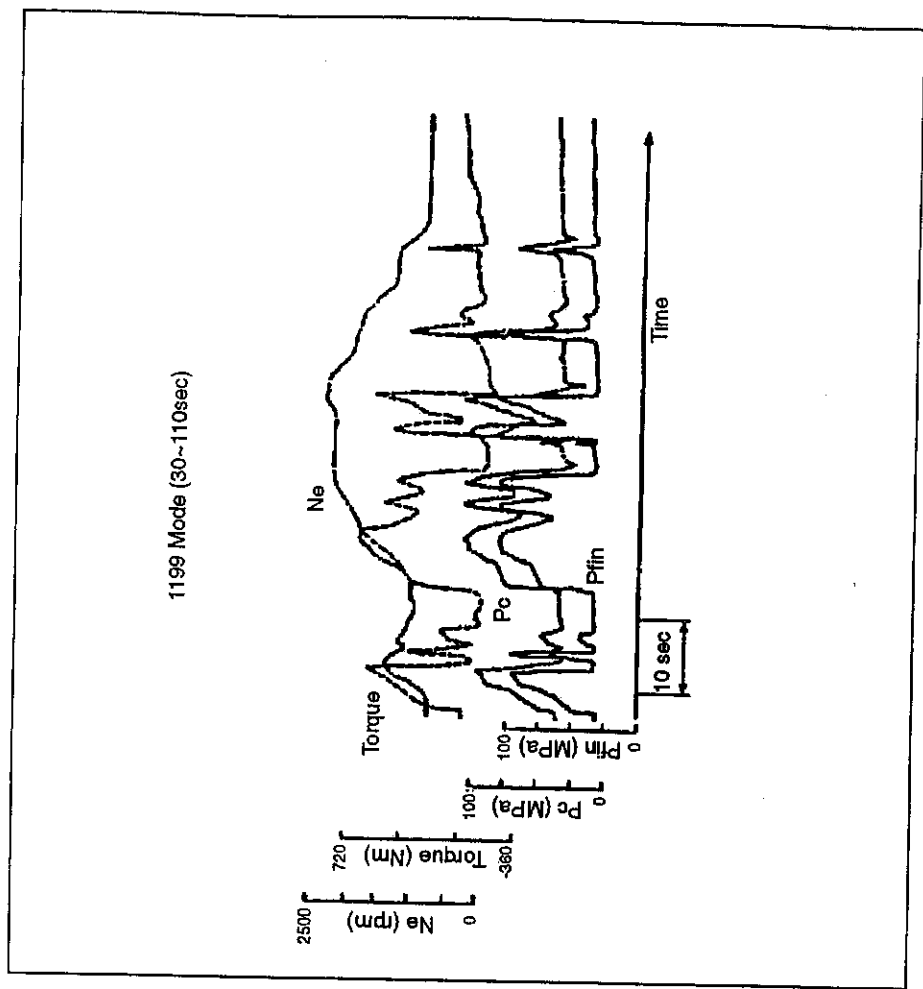

Figure 11: Pressure response at transient condition

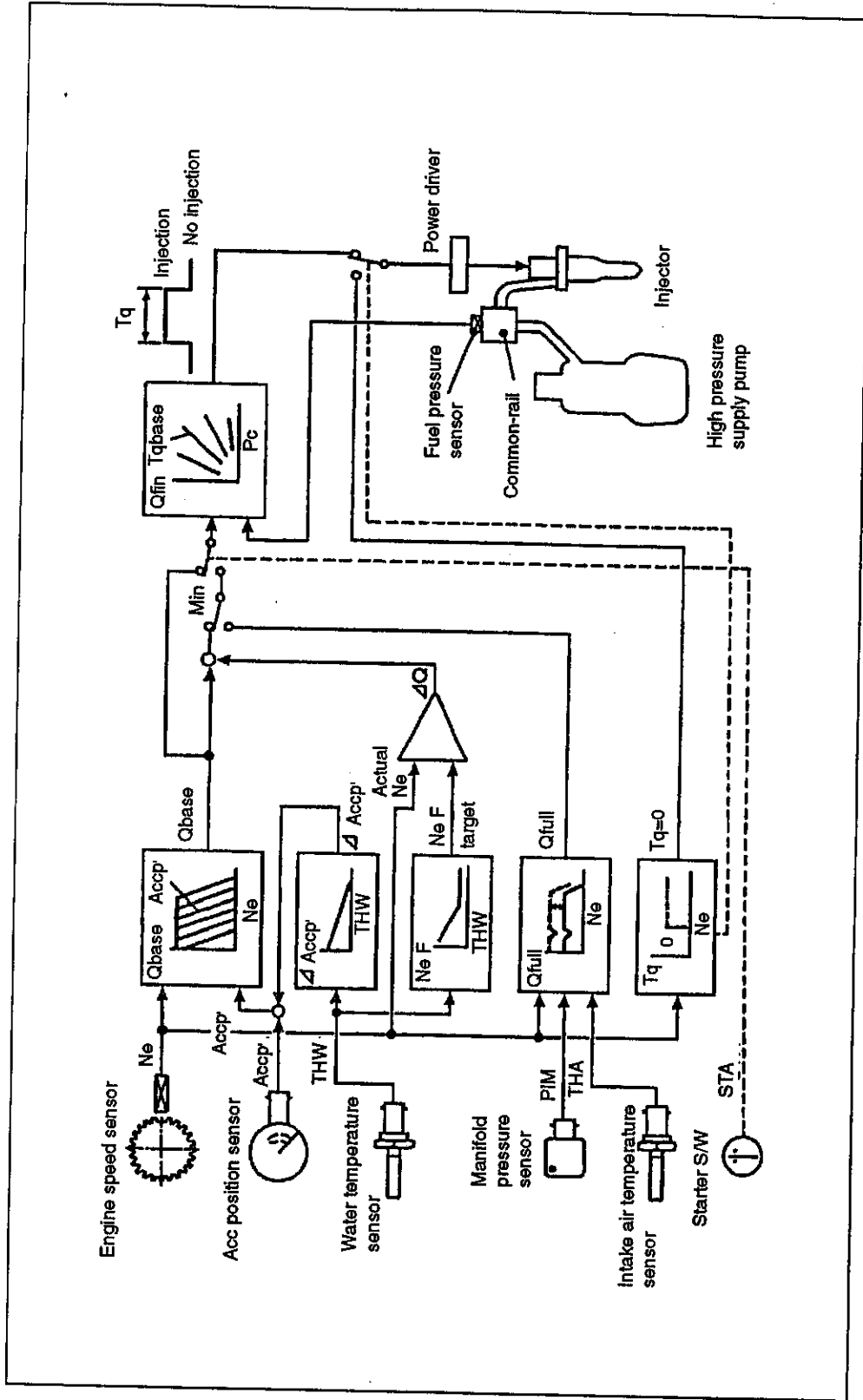

Figure 12: Block diagram of injection quantity control

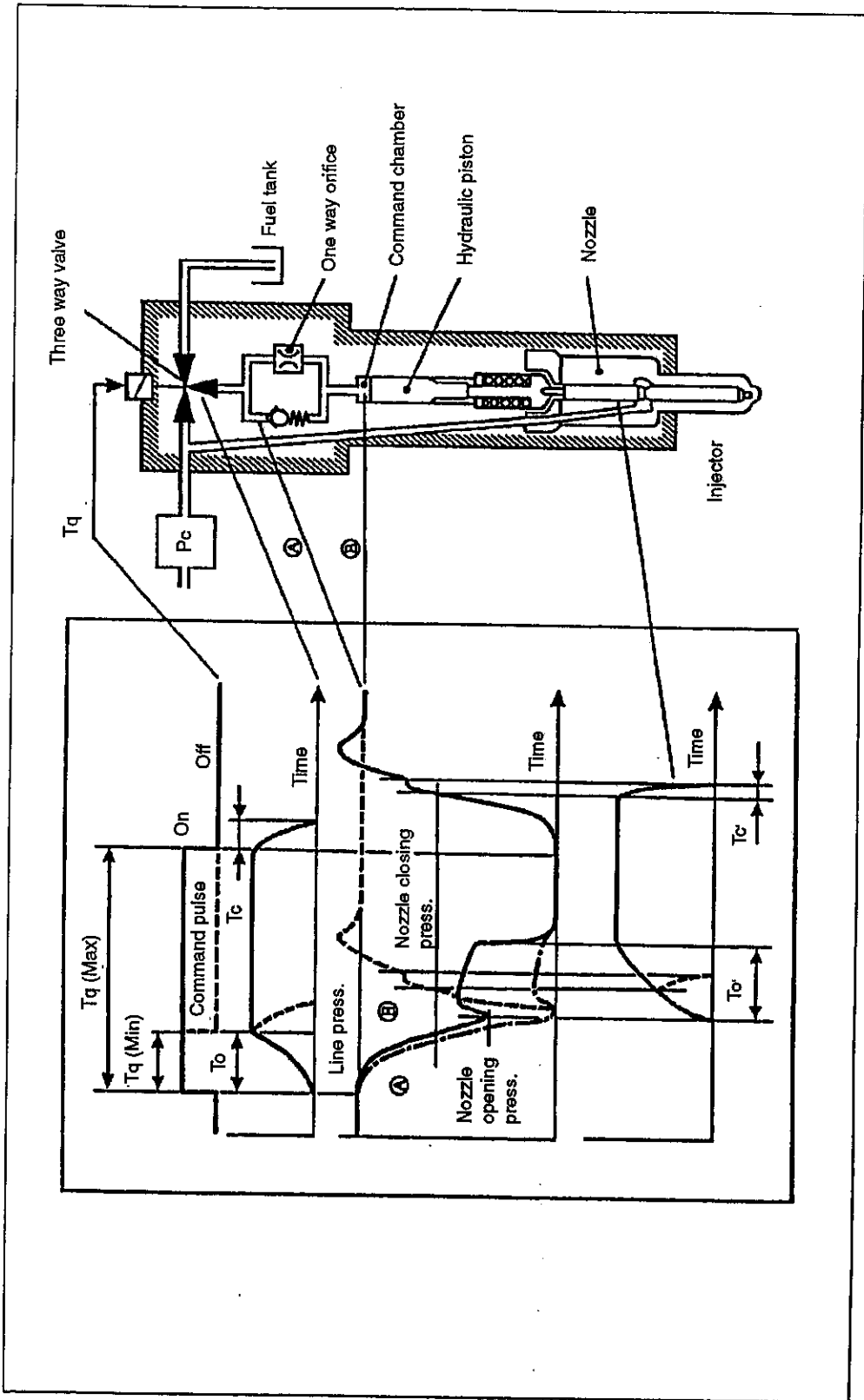

Figure 13: Fuel quantity control strategy

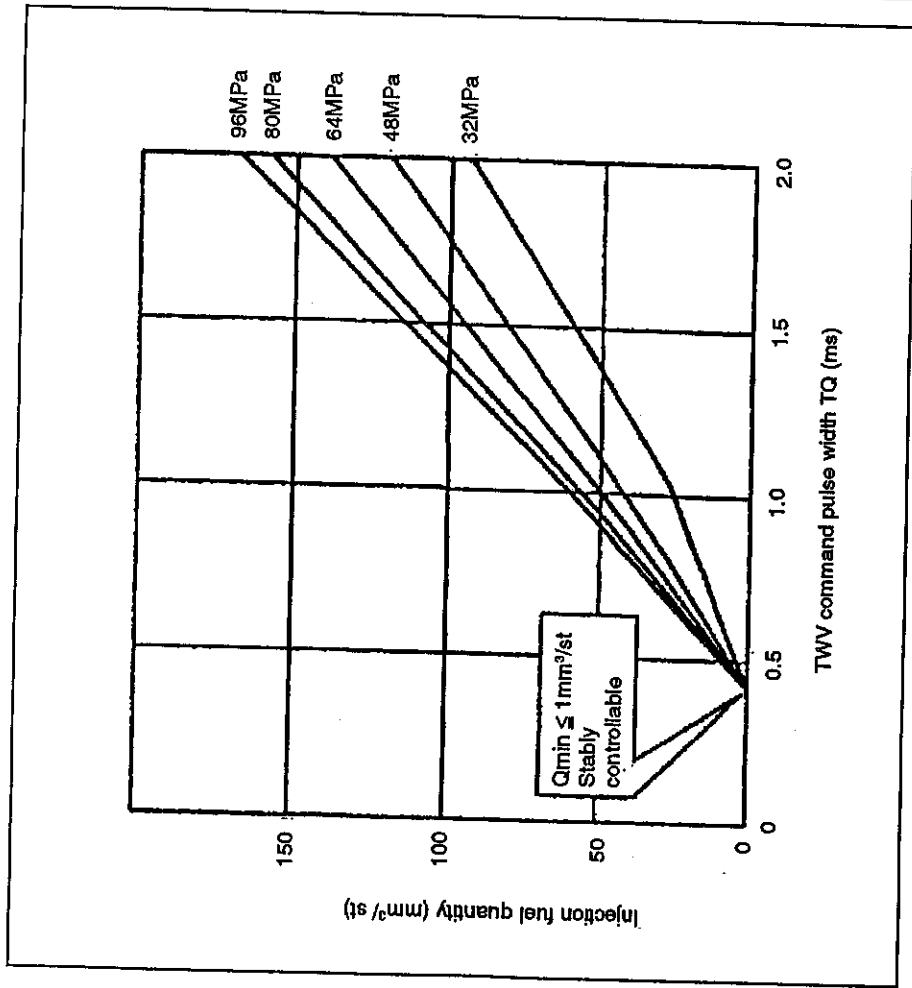

Figure 14: Fuel quantity control characteristics

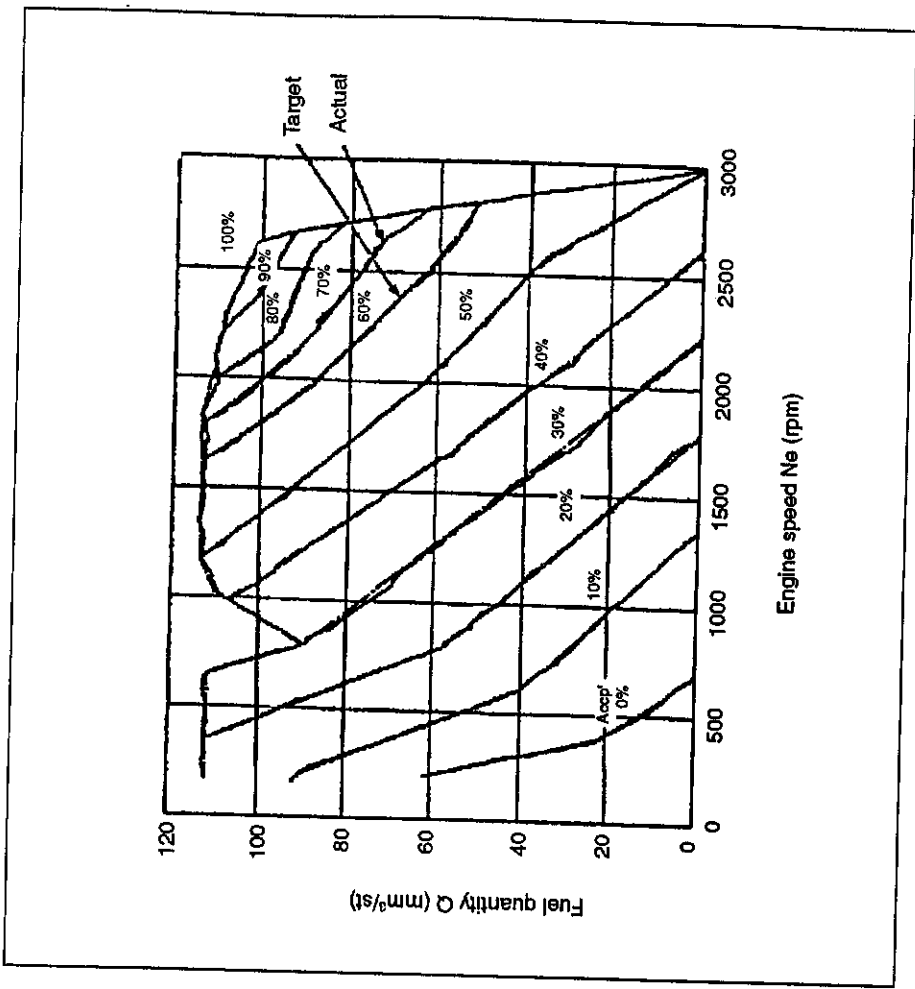

Figure 15: Fuel quantity control

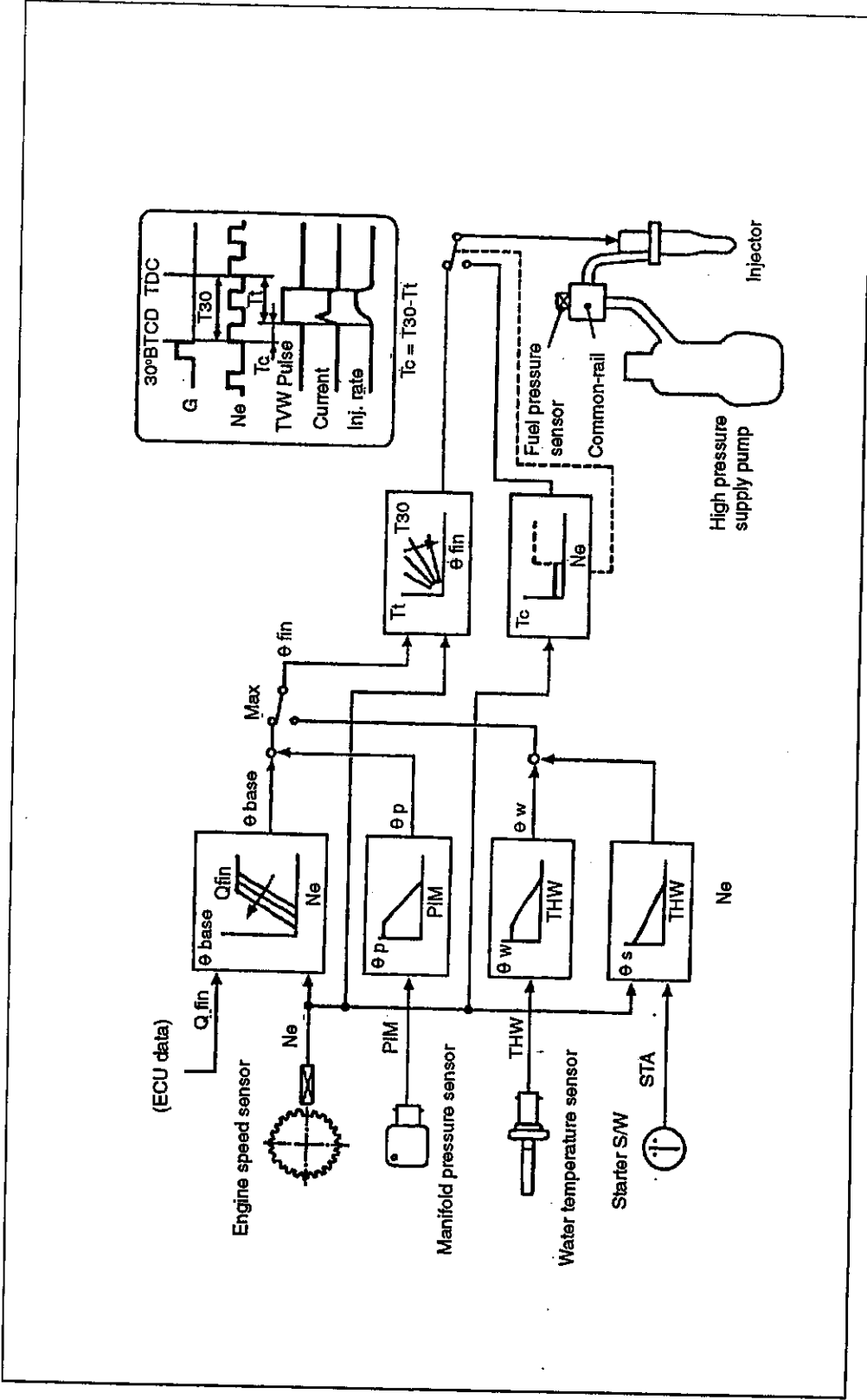

Figure 16: Block diagram of injection timing control

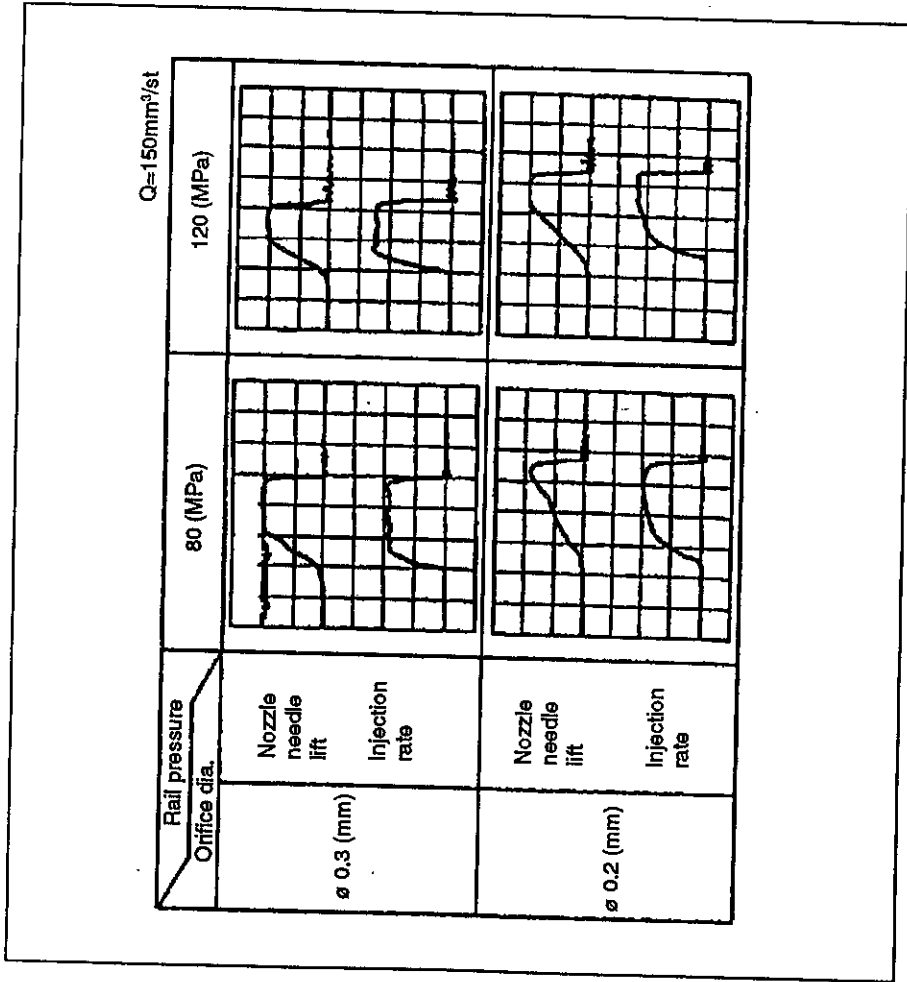

Figure 17: Delta shape injection rate

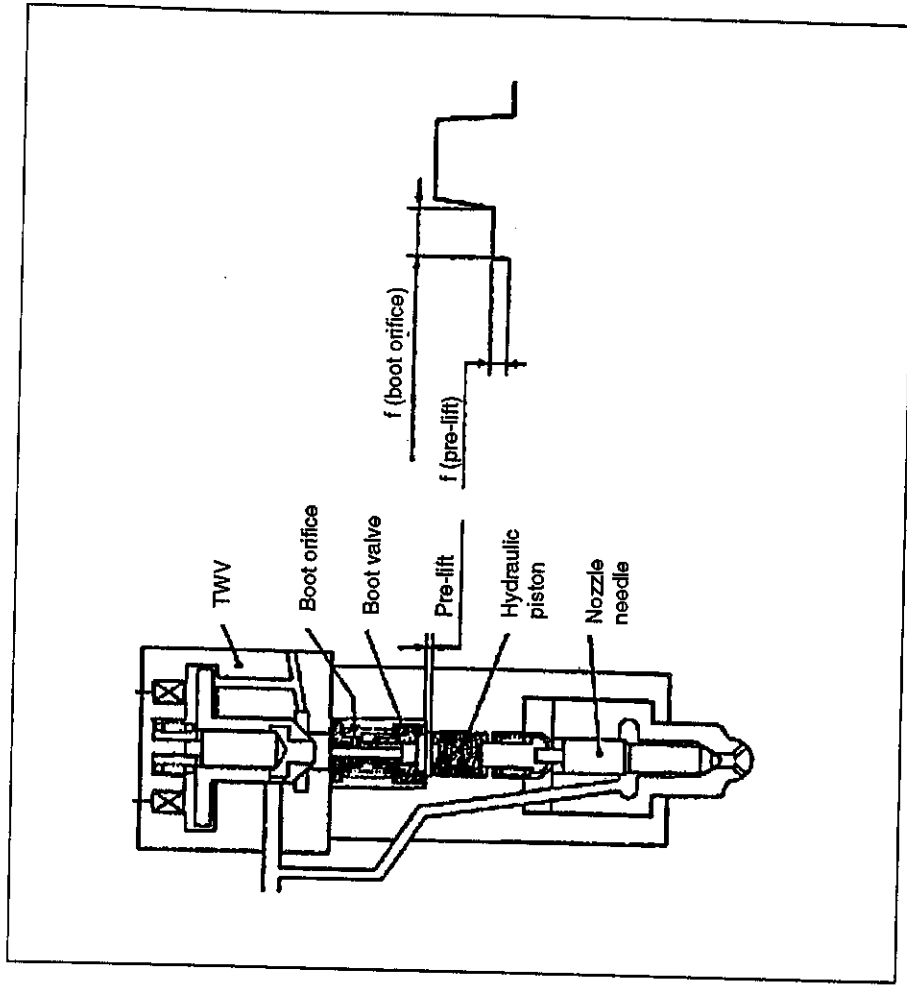

Figure 18: Structure of injector for boot shape injection rate

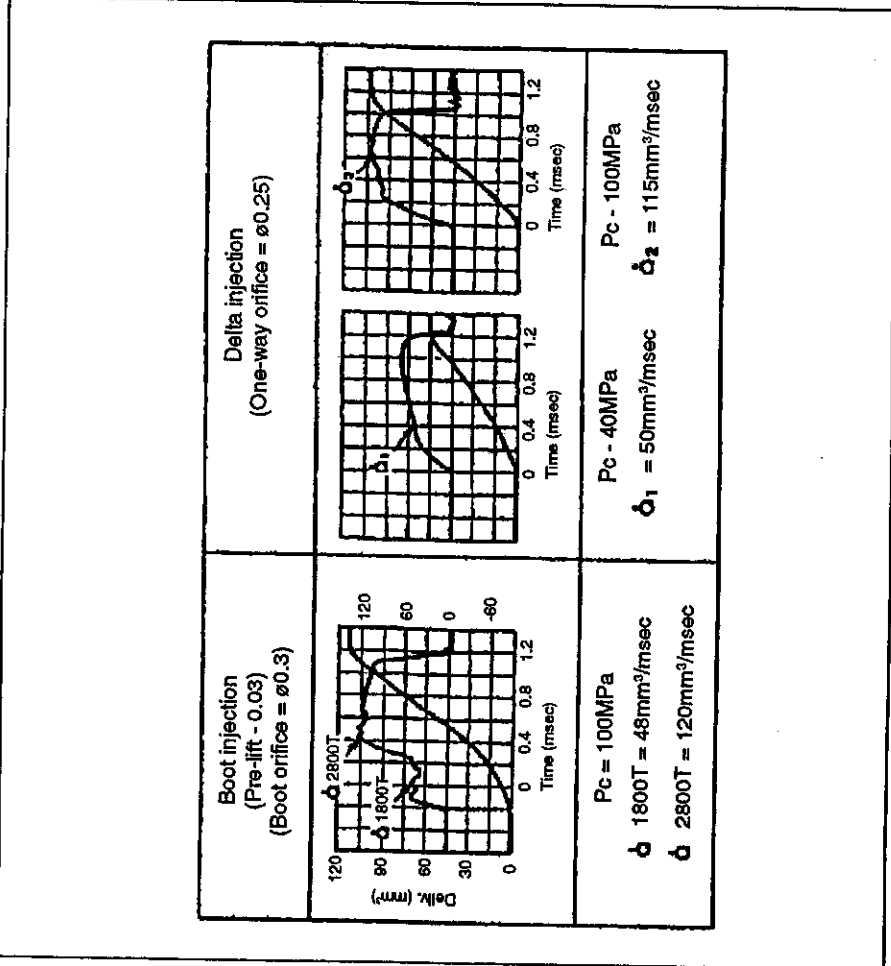

Figure 19: Boot shape injection rate

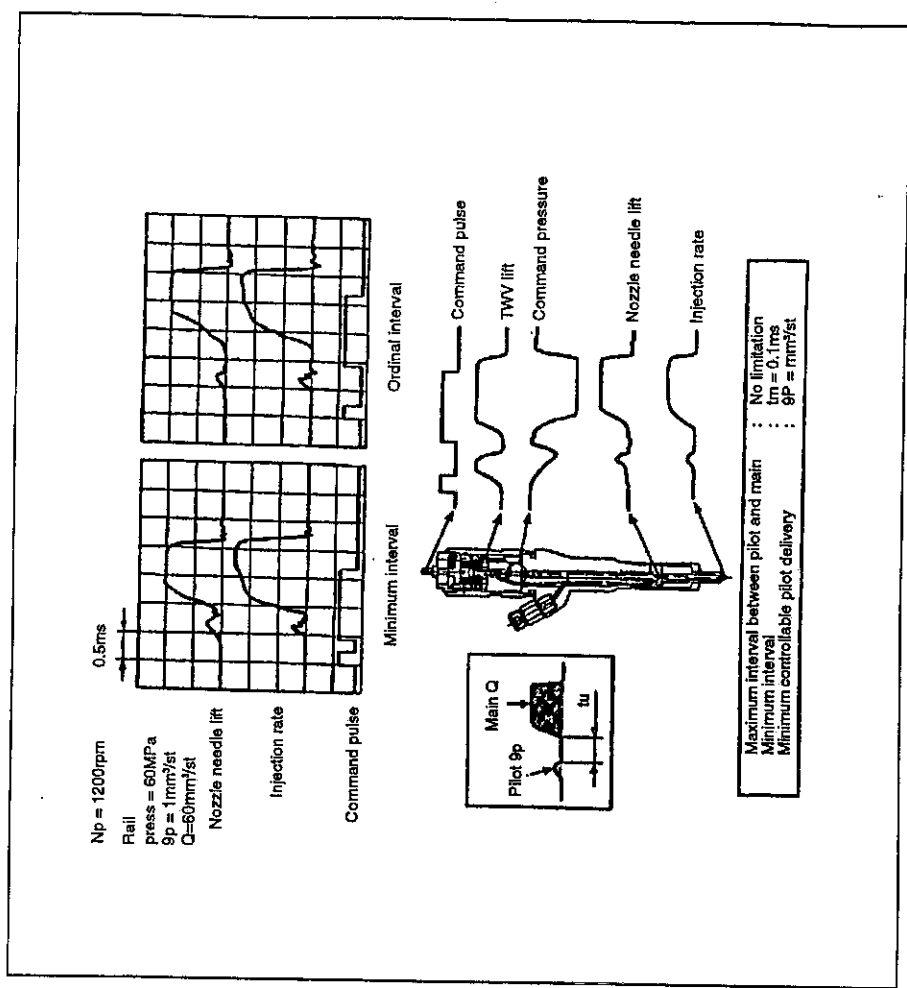

Figure 20: Pilot injection rate